

1. Description of Product

LAX-20C series is automatic changeover regulator for LP Gas liquid phase.

With a special cam adopted inside, the automatic liquid LPG changeover regulator, LAX-20C, provides an automatic valve changeover function through the combination of the fluid pressure and the spring load as the source of driving power. In addition, the product can positively actuate the valve even when the inlet pressure is very close between the left and right sides.

■ Breakthrough mechanism

A special cam is adopted in the valve changeover section. In addition, valve changeover is automatically conducted through the combined use of the fluid pressure and the load of spring at the same time.

■ Only small amount of gas remains in a used cylinder, improving the economy.

The changeover pressure can be set to a very low level, which permits only a small amount of liquid to remain in used cylinders.

■ Few action errors

Since the valve is switched automatically, action errors to the set changeover pressure are very few, which ensures positive valve changeover.

■ Light and small

Compared with conventional products, the changeover regulator is manufactured extremely small and light, so the user can mount the equipment very easily.

■ Status of valve action is quite obvious.

A large semispherical signal is equipped, and operators can identify the condition of action at a glance from the sides as well as from front.

■ Direction of supply is quite obvious.

The supply side is conspicuously identifiable due to the large changeover handle.

■ Easy change of supply direction

Just turn the changeover handle to the opposite side, and the supply direction will be switched.

■ Automatically notifies the information of cylinder replacement (only for LAX-20C-R).

Performed cylinder replacement is automatically informed to the control center via the telephone circuit, which eliminates the risk of gas shortage.

1-1. Specifications

Gas type	LPG ;liquid phase					
Maximum capacity	300kg/h					
Changeover pressure	0.05 ~ 0.15MPa					
Margin of error at changeover pressure	±0.01MPa					
Required inlet pressure (minimum value at reserve side)	[Changeover pressure + ΔP] to 1.56MPa ; where the value for ΔP is as follows;					
	Q; Capacity (kg)	100	150	200	250	300
	ΔP (MPa)	0.03	0.07	0.11	0.14	0.18
Pressure for pressure test	2.70MPa					
Pressure for gas-tight test	1.80MPa					
Outlet connection	Equivalent to JIS 20K Flange 20A ×2					
Inlet connection	Equivalent to JIS 20K Flange 20A					
Dimension	(W) 275mm × (H) 69mm					
Weight	9.5kg					

Specifications for Built-in Limit Switch of LAX-20C-R; Be sure to install an intrinsically safe apparatus.

Maximum operating voltage	DC30V
Maximum operating current	DC30mA
Contact resistance	1Ω or less
Insulation resistance	100M Ω or more
Withstand voltage	1000VAC or more

1-2. Name of parts

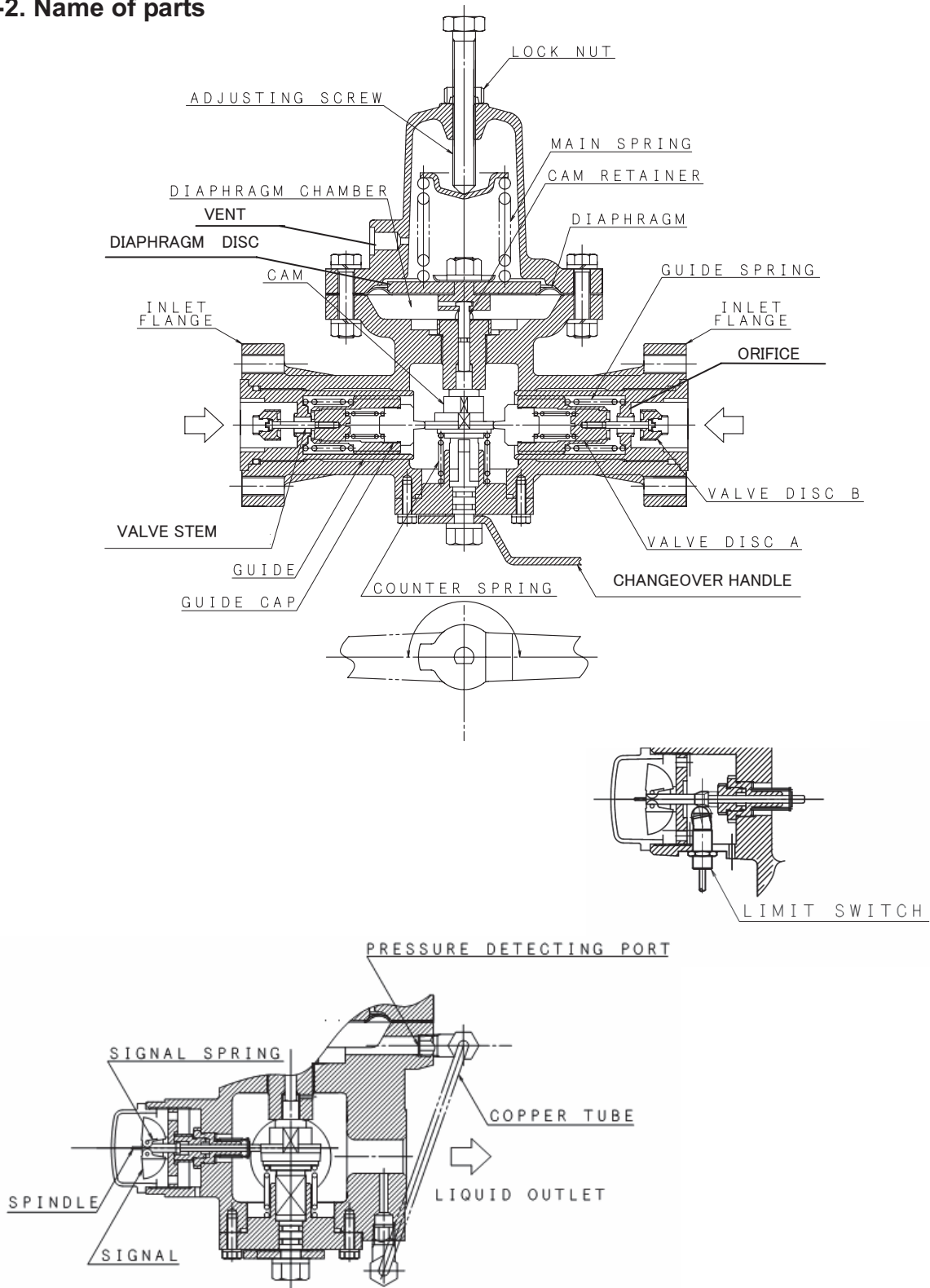

2. Outline of Functions

①When the supply pressure from the service side is substantially higher than the changeover pressure, the supply pressure runs through the copper tube, and enters into the diaphragm chamber to press up the diaphragm, keeping the valve discs A and B open on the service side. **Diagram A**

②As the supply pressure gradually lowers, the diaphragm is depressed little by little, and in conjunction with this, the cam retainer presses down the cam. **Diagram B**

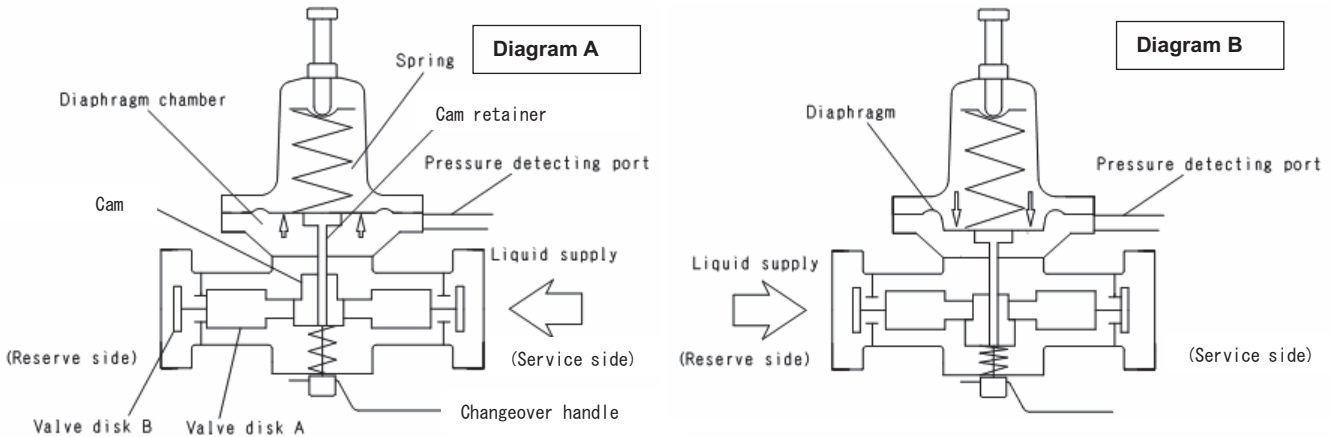

③When the cam lowers, the tip of the guide cap, which has been pressed against the lower stage of the cam, moves to the upper stage.

Fig. 1 → **Fig. 2**

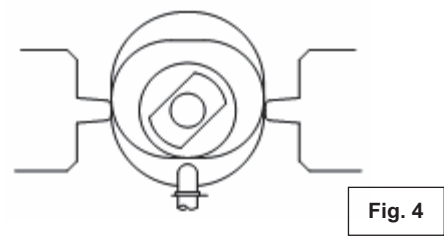
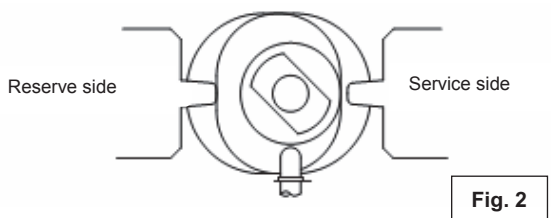
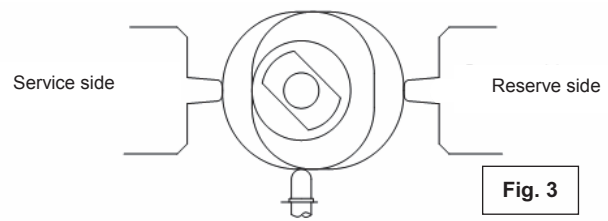
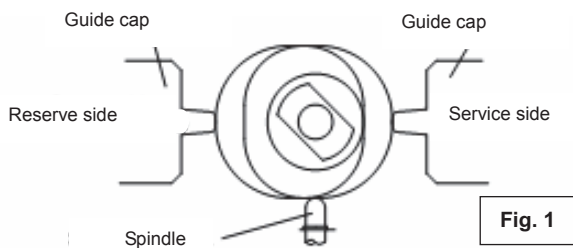
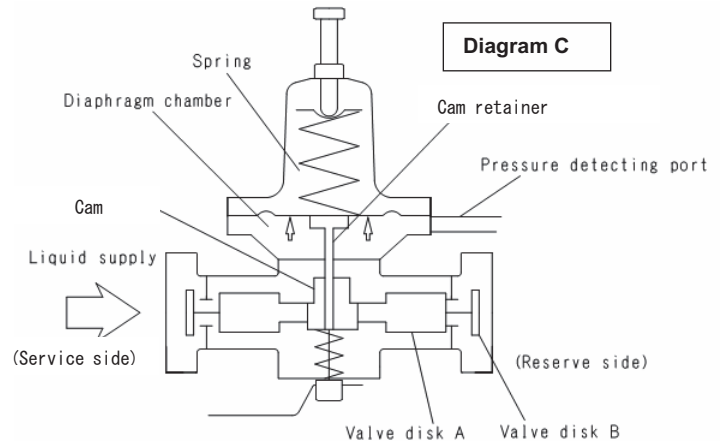

④Simultaneously with Step (3), the valve disc B on the service side closes its flow passage in conjunction with the guide cap in order to stop the supply on the service side. In the similar manner, the flow passage on the reserve side is opened to start a supply from the reserve side. **Diagram B**

*When the spindle, which has been pressed against the cam, moves to the upper stage of cam, the signal turns to "Red", indicating that the system has entered in the reserve-side supply mode (then the limit switch is turned ON if the product is equipped with a transmission functions).

⑤ Replace the cylinder on the service side, which has been emptied, with a filled cylinder.

*When the mode is switched to reserve-side supply mode, a pressure that is sufficiently higher than the set changeover pressure is applied to the diaphragm chamber. This pressure gets over the spring load to press up the diaphragm. At this moment, the cam is prevented from rising by the tip of guide cap and the spindle, and the valve disc B on the service side keeps remaining closed.

Diagram B Fig. 2

⑥ After replacing the cylinder, turn the changeover handle by 180 degrees to reset the signal.

i) If the changeover handle is turned by 90 degrees, the cam will rotate, and the guide cap on both sides will be pushed by the cam, and it will move to the lower stage of cam. **Diagram C Fig. 3**

ii) Turn the changeover handle by additional 90 degrees, and the spindle, pushed by the cam, will move to the lower stage, and the signal will turn to "White", indicating that the system has been reset (the direction of supply from the cylinder agrees with that of changeover handle).

Diagram C Fig. 4

⑦ The series of above operations enables the user to continually switch the flow passage of LPG liquid supplied from two lines.

3. Switching Pressure Setting



When setting or changing the changeover pressure value, follow the procedure below.

- ① Ease the hexagon nut and rotate the adjusting screw freely to the left and right with spanner or monkey wrench.
- ② Rotate the adjusting screw to the right, the spring will be compressed and the changeover pressure will be higher. Conversely, rotate the screw to the left, and the adjusting pressure will be lower.
- ③ As shown in the diagram below, determine the dimension, H, which corresponds to your desired setting pressure, and set the adjustment screw to that height.

Example: Dimension H = approx. 20 mm for the changeover pressure = 0.12 MPa

- ④ After setting the changeover pressure, tighten the hexagon nut and fix the adjusting screw.

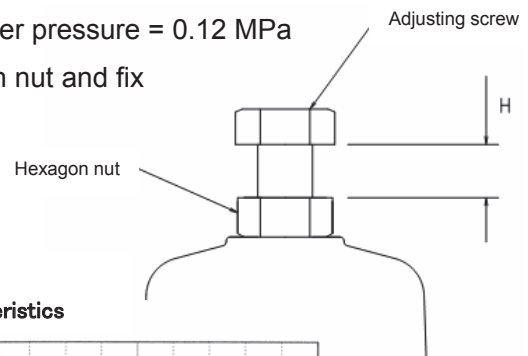

Conduct an operation test and fine-adjust the setting pressure before operation.

